

StrapPack[®]

Automatic Strapping Machine



RQ-8

RQ-8

High-Performance Automatic Strapping Machine

■ Amazing Strapping Speed

1.5 seconds per strapping cycle – That's 40 straps per minute!

■ Self-Correcting Technology

Unique self-correcting mechanisms are built into the RQ-8 operation. If the RQ-8 is operated accidentally without a package on the table, the strap will form a small loop which will be automatically ejected from the sealing unit leaving the machine ready for the next cycle.

■ Easy Strap Loading

Newly developed loading system free of complicated devices makes strap threading almost completely automatic – it's just a touch of a lever.

■ Permanently Lubricated Mechanisms

Strapack's self-lubricating design has an unsurpassed reputation for its durability and maintenance-free operation.

■ Quick Heater

Ready to operate in less than 25 seconds. Designed to insure high seal joint.

■ Self-diagnostic

A programmable microprocessor constantly monitors critical functions. Any irregularity sensed is immediately displayed.

■ Portable

Heavy-duty metal casters allow for the machine to be quickly installed or moved to any Single Phase power supply outlet.

■ Variable Tension

A wide range of tension is available to the operator by use of a single tension dial. Tension capability up to 80kg (equivalent to 150mm stroke).

■ Dependable

Strapack's advanced bandway design assures perfect strap placement and eliminates any twisted straps.

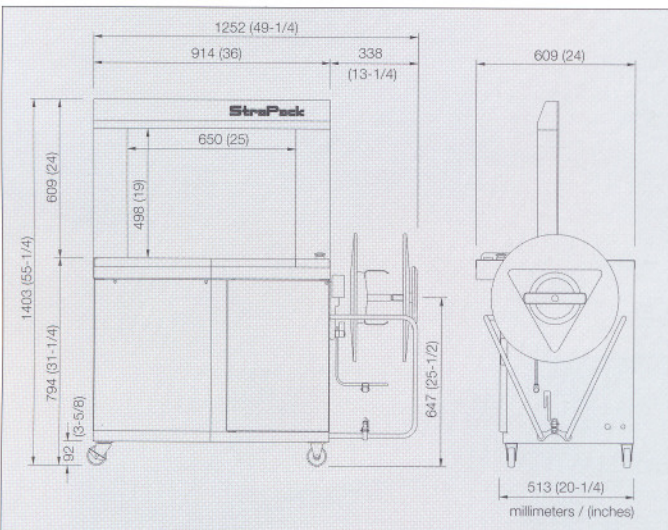

■ Arch Size Chart

Size in mm/(inches) § standard size

H \ W	650 (25)	850 (33)	1050 (41)	1250 (49)	1450 (57)
400 (15)					
500 (19)	§				
600 (23)					
800 (31)					
1000 (39)					

*:Availability of arch sizes may be limited depending on strap width.

■ Standard Specifications

Dimensions	Width	1252mm	49-1/4 in.
	Height	1403mm	55-1/4 in.
	Depth	609mm	24 in.
	Weight	160kg	353 lbs.
Table Height		794mm	31-1/4 in.
Arch Size		W 650 × H 500mm	W 25 × H 19 in.
Package Size	Max	W 620 × H 480mm	W 24-1/2 × H 18-7/8 in.
	Min	W 80 × H 30mm	W 3-1/8 × H 1-1/4 in.
Joint / Strap / Coil		heat seal / polypropylene / ID 200 × OD 450 × W 200mm	heat seal / polypropylene / ID 8 × OD 18 × W 8 in.
Strap Width		5, 6, 9, 12mm	1/4, 3/8, 1/2 in.
Strap Tension		up to 784N (80kgf), 150mm stroke	up to 176 lbf, 5-7/8 in. stroke
Speed		1.5 sec. / strap, 40 straps per min.	
Power Supply		100, 120, 200, 220, 230, 240V	single phase 50 / 60Hz 0.65KVA

Modification rights reserved.

Pats., U.M. & design registered and/or pending.

© 2003 Strapack Corporation

DISTRIBUTED BY: