

Wrapping Technology

Automatic stretching
in the line

Automatic Stretchwrapper GL 2000

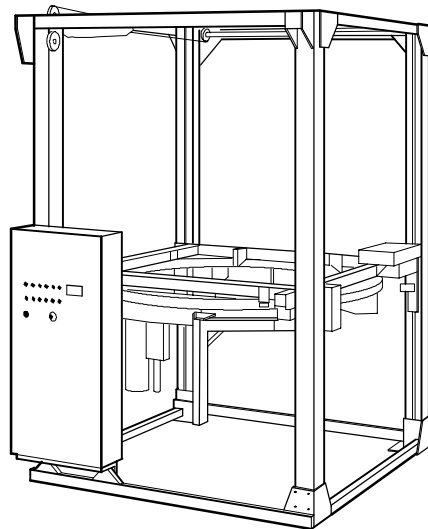

Options

CONTENTS

ART. NO.	PRICE	DESCRIPTION	PAGE
1030000		GL 2000 – Automatic Stretchwrapper	4
OPTIONS			
620010		Custom color	5
620046		Pallet control	5
620048		Pallet check, in & out conveyor	5
620049		Top platen	6
620056		Height seeking device	6
620067		Extension feet	6
620112		Lightbeam, one side	7
620113		Lightbeams, two sides	7
		Lightbeam, software	7
620120		Welding unit	8
620159		Film alarm	8
620190		Guarding, machine	8
620202		Modem for communication	9
620205		Remote setting of pre stretch	9
620207		Guarding, in & out conveyor	9
		90 degree kit	10
		Extended masts	10
		Extended ring	10
		Control of conveyor in machine	11
		Extended memory 2 Mb	11
		ITF – Integrated Top Sheet Dispenser	11
ACCESSORIES			
		Loader for top film	12
620006		Lifting trolley	12

GL 2000 – AUTOMATIC STRETCH WRAPPER

Art. No.

Info

1030000 Standard GL 2000.

Length: 2,4 m

Width: 2,8 m

Height: 3,8 m

Weight: kg

Goods dimensions

Max height: 2,5 m

(at transport height 300 mm)

Max weight: not applicable

Max L x W: 1,2 x 1,2 m or

L x W: 1,4 x 1,0 m

Max diameter of goods: 1,72 m.

(Measured between opposite corners).

PLC: Siemens S7

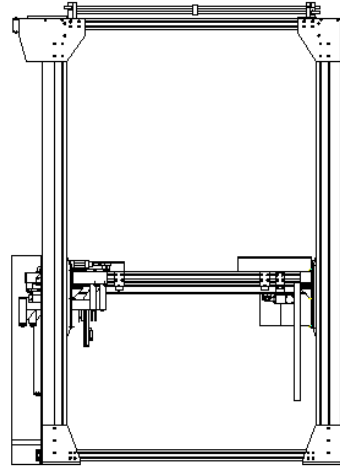

GL2000 with transport security frame mounted.

CUSTOM COLOR

Art. No.	Info
-----------------	-------------

620010	Custom color on, for example, the ring, cabinet, battery box and so on.
--------	---

PALLET CONTROL

Art. No.	Info
-----------------	-------------

620046	Controls where the pallet are in the machine, and how big it is in one axis. 2 will be needed to determine the position both length- and width-wise.
--------	--

PALLET CHECK, IN & OUT CONVEYOR

Art. No.	Info
-----------------	-------------

620048	Controls that no pallet is situated on the conveyor to make sure that the ring can move freely. Order two to control both in- and out-feed conveyor.
--------	--

TOP PLATEN

Art. No.	Info
----------	------

620049	With the ITF a top film can be put on the goods to receive a dustproof or a waterproof pallet. Can take film widths between 1200 and 1600 mm.
--------	---

Attention!
Waterproofing will decrease the capacity.

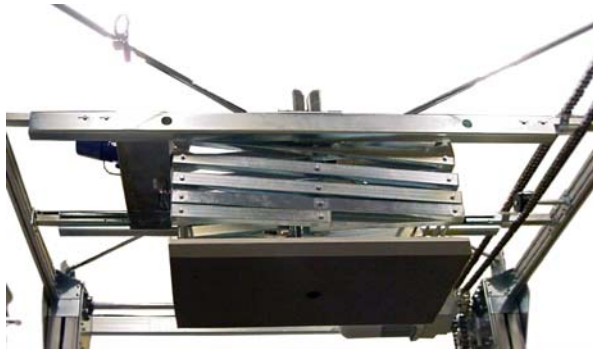

HEIGHT SEEKING DEVICE

Art. No.	Info
----------	------

620056	Scans the pallet to detect the height of the goods.
--------	---

EXTENSION FEET

Art. No.	Info
----------	------

620067	Extends the machine 500 mm. Can be made to custom height.
--------	--



LIGHTBEAM, ONE SIDE

Art. No.	Info
-----------------	-------------

620112	A safety option that contains a SICK lightbeam for monitoring one side of the machine.
--------	--

LIGHTBEAMS, TWO SIDES

Art. No.	Info
-----------------	-------------

620113	Same as above, but with two SICK lightbeams for monitoring two sides.
--------	---

LIGHTBEAM, SOFTWARE

Art. No.	Info
-----------------	-------------

WELDING UNIT

Art. No.

Info

620120 This is an option where plates weld the end of the film to the pallet.

This is to prevent loosely hanging film ends which can cause problems during transportation and other handling of the pallet.



FILM ALARM

Art. No.

Info

620159 Film almost end is an option where the operator gets a light signal to warn that the film roll is about to come to an end.

This option helps to decrease the stand still time for changing of the film.

GUARDING, MACHINE

Art. No.

Info

620190 Guarding for the GL 2000. Also includes a door.

Total height: 2300 mm, whereof the net is 2200 mm high.

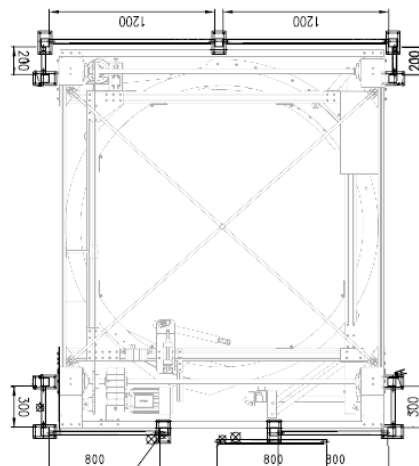

MODEM FOR COMMUNICATION

Art. No. Info

620202 Modem which makes it possible to do changes in the program without being at the customer.



REMOTE SETTING OF PRE STRETCH

Art. No. Info

620205 Choose desired gear from the display on the front of the electrical cabinet.

The picture shows the servo motor.



GUARDING, IN & OUT CONVEYOR

Art. No. Info

620207 Guarding of the in- and/or out-feed conveyors.

Total height: 2300 mm, whereof the net is 2200 mm high.

Order 2 for both in- and out-feed conveyor

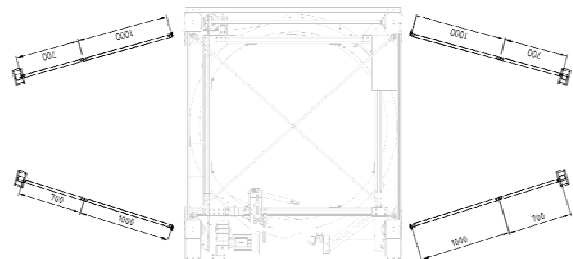

90 DEGREE KIT**Art. No.****Info**

The 90 degree option is used when a straight line of transportation through the machine is not possible.

For 90 degree in or out transportation.

EXTENDED MASTS**Art. No.****Info**

Higher GL2000. Used when you have high pallet loads. For pallets with height 1600 mm up to 3100 mm.

EXTENDED RING**Art. No.****Info**

By moving the aggregate and the battery compartment, the GL2000 will manage +100 mm bigger pallet.

Max pallet size: 1820 mm.
(Measured corner to opposite corner).



CONTROL OF CONVEYOR IN MACHINE

Art. No.

Info

Hardware and program for controlling af and conveyor in the GL2000.

EXTENDED MEMORY 2 MB

Art. No.

Info

ITF – INTEGRATED TOP SHEET DISPENSER

Art. No.

Info

With the ITF a top film can be put on the goods to recieve a dustproof or a waterproof pallet. Can take film widths between 1200 and 1600 mm.

Attention!
Waterproofing will decrease the capacity.



LOADER FOR TOP FILM**Art. No.****Info**

Helps loading the roll of top film into the ITF in an easy way.

**LIFTING TROLLEY****Art. No.****Info**

620006 A lifting trolley to help loading of the stretch film rollers in the GL2000.

