

Stretch Wrapper GL 200

"A reliable, rigid and cost efficient machine"

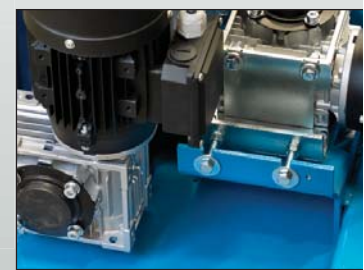



Stretch Wrapper GL 200

Overview and dimensions

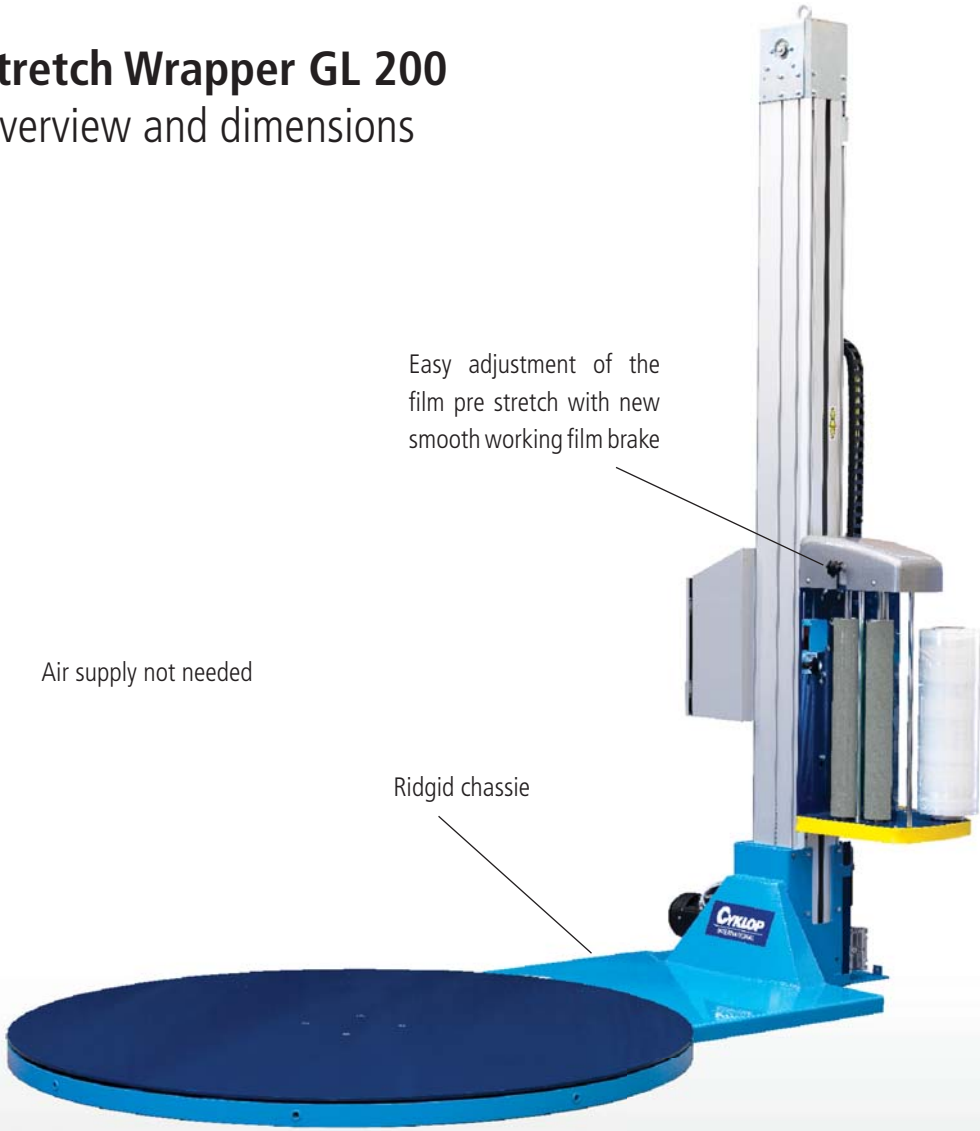

Easy adjustment of the film pre stretch with new smooth working film brake

Air supply not needed

Rigid chassie

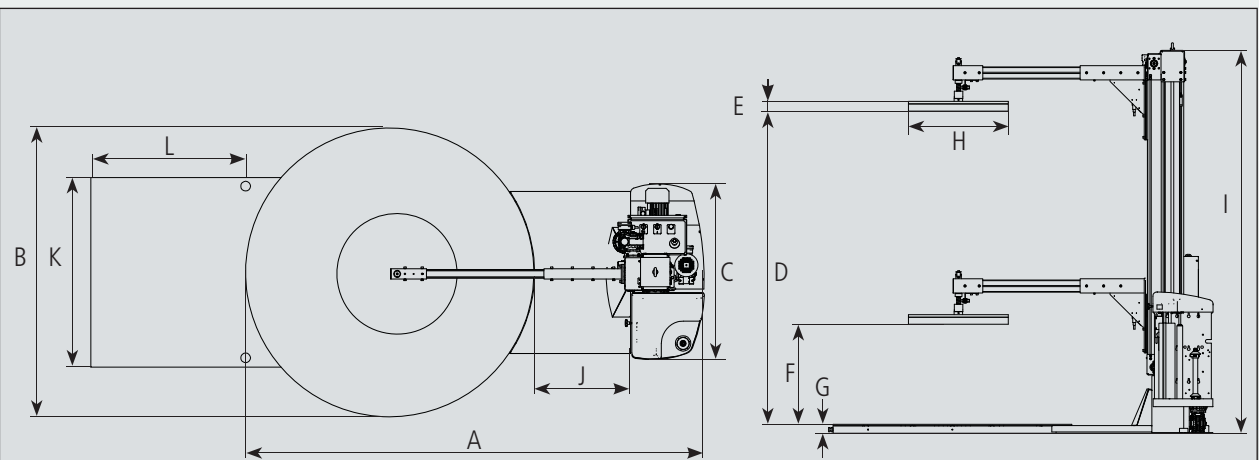

Dim (mm)	A	B	C	D	E	F	G	H	I	J	K	L
Standard	2670	1675	1020	2200	50	750	60	700	2670	550	1100	900
Option	2995	2000	1020	2600	50	750	60	700	3070	550	1100	1500

Weight, standard: 500 kg (Weight can vary depending on options). Crated dimensions: L2900 x H1050 x W1800 mm, weight: 650 kg.



Stretch Wrapper GL 200 Specification

Operator starts wrap cycle at machine. Operator manually cuts/attaches film.

Machine	Table diam	1675 mm			
	Table speed	Max 12 r.p.m adjustable			
	Soft start / stop	Electronically run			
	Stretch wrapping programs	5 standard, 1 for manual operation			
	Bottom/top wrappings	Prog 1	2 bottom	1 top	Stops in top
		Prog 2	3 bottom	2 top	Stops in top
		Prog 3	2 bottom	1 top	Up/down
		Prog 4	3 bottom	2 top	Up/down
		Prog 5	4 bottom	3 top	Up/down
		Prog 6	Manual setting		
Film carriage speed	Variable film overlapping top and bottom				
Pre stretch / Film tension	Adjustable, friction brake				
Controller	Siemens PLC				
Power	Supply	230/400 V, 3-phase, 50 Hz			
	Protection	IP51			
Pallet Goods	Max size (length x width)	1200 x 1200 mm			
	Highest goods height incl pallet	2200 mm (standard machine)			
	Max load weight	1500 kg			
Stretch Film	Core diameter	76 mm			
	Outer diameter, max	250 mm			
	Film width, max	500 mm			
	Film thickness	15-35 my			
CE-mark	(EN 60204)				

Stretch Wrapper GL 200 Options

- Top platen (round / rectangular)
- Turntable diam 2000 mm
- Extended mast
- Extended chassis
- Access ramp
- Galvanized chassis
- Top film cassette



GL 200 equipped with the
option top plate

Stretch Wrapper GL 200

Wraps up to 50 loads per day. For low volume users in lines of businesses. Wraps irregular shaped loads. Uses pallet truck to load stretch wrapper. Operator starts wrap cycle at machine and manually cuts/attach the film.

Levels of automation based on long experience, extension possibilities and a large number of settings give this new series of stretch wrappers a high profitability through optimal adaptation to every need. These properties guarantee a good protection and transport packaging as well as the lowest possible material cost.

Easy to operate

- Controls are easy to find and understand.
- Foldable mast and fork truck voids are fitted for easy in-transport and good mobility.
- Fast and simple film roll changes.
- Automatic load height sensor.
- Air supply not needed.

Consistent packaging result

- Flexible setting possibilities enable optimum packaging for a variety of goods.
- 5 programs are factory preset with one additional for manual operation.

Key features:

- Easy change of programs and settings.
- Easy adjustment of the film pre stretch with new smooth working film brake.
- Manual mode.
- The GL 200 allowing both low pre-stretched films and pre-stretched film rolls to be used.

Stretch Wrapper GL 200

Operator panel

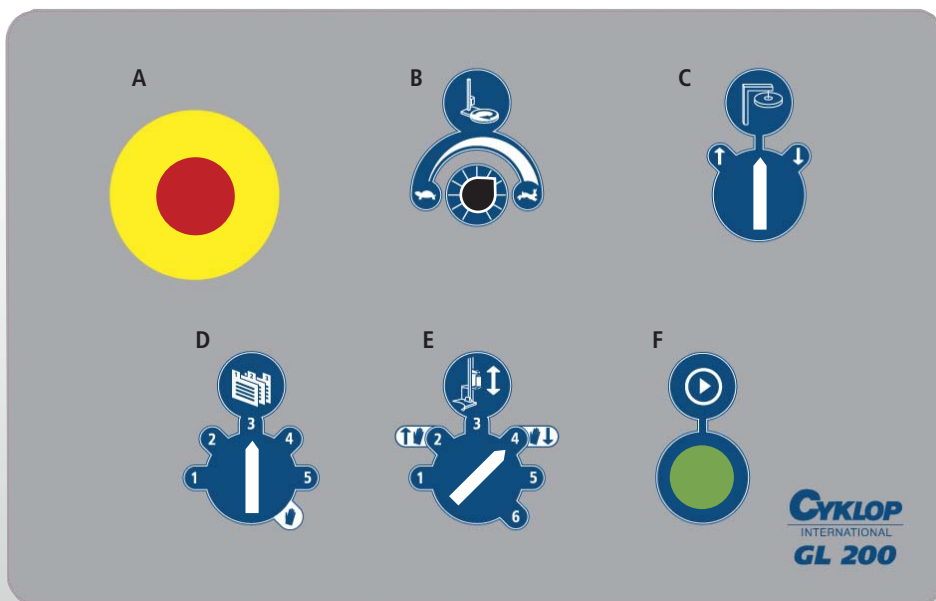

- (A) Emergency stop
(B) Turntable speed
(C) Top plate (Option)

- (D) Program selector
(E) Film carriage speed / manual up & down
(F) Start

CYKLOP
INTERNATIONAL